

Georgia Vocational Rehabilitation Services (GVRS) Board Meeting

Wednesday, August 25th, 2021



GVRA



GVRA



Georgia Vocational
Rehabilitation Agency

Chairman's Welcome

- Welcome & Remarks
- Roll Call and Agenda
- Previous Board Meeting Minutes Approval

Executive Report

Chris Wells, Executive Director

chris.wells@gvs.ga.gov



GVRA



GVRA



Georgia Vocational
Rehabilitation Agency

Table of Contents

- Efficiency Changes
- Highlights by Program



Georgia Vocational
Rehabilitation Agency

Program Highlights

- **Disability Adjudication Services (DAS)**
 - **SSA Workload Goals**
 - With 88.5% of the FFY completed, DAS has processed 96.9% of projected workload (77,593 cases)
 - **Accuracy of Disability Decisions**
 - Initial Case Accuracy Performance for rolling 3 month quarter ending July 2021 is 94%; higher than both regional and national.
 - **Hiring**
 - On-boarded 61 of the allocated 104 hires; expect to higher another 15 by September 16th.
 - Extension requested through 1st quarter of FFY 22.
 - Additional hires are expected to be allocated in FFY 22



Program Highlights

- **Business Enterprise Program (BEP)**
 - BEP has begun reopening several State-owned facilities, including 200 Piedmont, and in South Georgia.
 - Reopening plans for federal facilities remains unclear.
 - BEP's Annual Blind Vendor Training Conference is scheduled for September 24-26, 2021.
 - DPH and CDC guidelines will be enforced; further updates are coming.
 - RSA's financial relief funds
 - Working to distribute Financial Relief and Restoration Payments (FRRP) to blind vendors affected by inventory loss during 2020.
 - At least 25 vendors have submitted the Vendor Management Forms (VMF) and are waiting SAO approval. Goal of all VMFs submitted by 8/31/21.



Program Highlights

- **Vocational Rehabilitation**

- 280 cases have been cleared from the Delayed Status List.
- 4 retirees will join by 9/1/21 to assist with the Overflow Project in Atlanta as well as the Rapid Response Team working on the Delayed Status List.
- Recently partnered with 3 community providers to deliver the GROW program to students with disabilities in northwest Georgia.
 - Over 20 students received industry tours, self-advocacy training and career exploration.
- 109 students in District 4 were referred for Pre-ETS services through GROW and Work Based Learning programs.

Departmental Administration

Jonathon Buxton, Director of Administration

Jonathon.buxton@gvs.ga.gov



GVRA





Georgia Vocational
Rehabilitation Agency

Agency Expenditures – SFY 2021

GVRA	Total Expenditures	Current Budget	Percent of Budget
300-Personal Services	\$75,908,496	\$76,464,274	99%
301-Operating Expenses	6,210,066	6,502,762	95%
303-Vehicle Purchases	14,100	14,100	100%
304-Equipment	1,569,149	1,570,151	100%
305-Computer Charges	4,772,758	4,777,774	100%
306-Real Estate Rentals	7,916,669	7,918,671	100%
307-Telecommunications	2,781,483	2,786,491	100%
309-Capital Outlay	388,350	1,403,125	28%
312-Contractual Services	12,791,760	13,366,508	96%
314-Transfers	20,564	17,618	117%
315-Grants and Benefits	30,377,125	30,898,627	100%
319-Other	962,699	1,015,710	95%
Total Expenditures	\$143,713,219	\$146,235,811	98%



Administration

- Fiscal –
 - FY 2021 budget review
 - FY 2022 budget alignment
 - Bond request submission planning

- Facilities –
 - Office relocations update

- IT –
 - Electronic signatures
 - Network infrastructure upgrades

Georgia Industries for the Blind

Raj Pagadala, Interim Director

Raj.Pagadala@gvs.ga.gov



GVRA



GVRA



Georgia Vocational
Rehabilitation Agency



- The AbilityOne Program is a **preferred source of supplies for federal employees**
- Government agencies prioritize the purchasing of products to suppliers that employ individuals who are blind
- **75%** of the organization's workforce must be either **blind or legally blind**



- NIB provides technical assistance and negotiates contracts on behalf of its agencies
- **Georgia Industries for the Blind is one of 100+ agencies that NIB supports**



- Mike Jackson retired as Director of GIB in Jul, 2021
- Chris charged Teresa and Raj to evaluate GIB and submit a report
- Report is intended to include **recommendations for:**
 - a) **Improvements** to GIB's manufacturing operations
 - b) **Expanding manufacturing market** by targeting State of Georgia and Private Sector
 - c) Maximizing potential of **mask manufacturing**
 - **Obtain ASTM Level 3 Certification**
 - d) Exploring options for GIB to diversify into **Services related model** (non-manufacturing)
 - e) New GIB **organizational and operational structure** that meets current and future needs

Timeline:

1. Preliminary Findings – Sep 2021
2. Final Report – Nov 2021



Methodology:

Georgia Industries for the Blind

1. **Learn** how GIB functions as a manufacturing facility
2. **Interview** GIB employees
 - a. Bainbridge
 - b. Griffin
 - c. Robins Air Force Base

National Industries for the Blind (NIB)

Work closely with NIB to:

1. Understand **GIB's limitations and opportunities**
2. Tap into NIB's internal resources:
 1. **Business Development Team** (Tom Black, Steve Overby)
 2. **Federal Contracts Support Team** (Ray Sullivan, Shawn Spengler, Laminka Jones, Mahala Langford, Elizabeth Sakmar etc)
 3. **Productivity Engineers** (Gigi Dottin, Danny Truenh, John Sorboro)
3. Network with other NIB agencies to leverage their expertise

State Government sector and private sector

Identify business partnership opportunities



Current Federal Contracts:

File Folders

- GIB manufactures file folders for federal government
- Supply chain issues due to COVID has resulted in unfilled orders
- Other NIB agencies are having similar issues

Pillows

- GIB manufactures pillows for the US Army and Navy

Kitting Projects

- Pistons Kits
- Windshield Wipers

Sewing Projects

- Parachute Deployment Bags

Future Projects

- GIB is working towards ASTM Level 3 Certification for it masks
- Provide masks to federal agencies and hospitals



Georgia Vocational
Rehabilitation Agency

Diversifying GIB to a Services Model:

- Next Steps for Exploring **Digitization**:

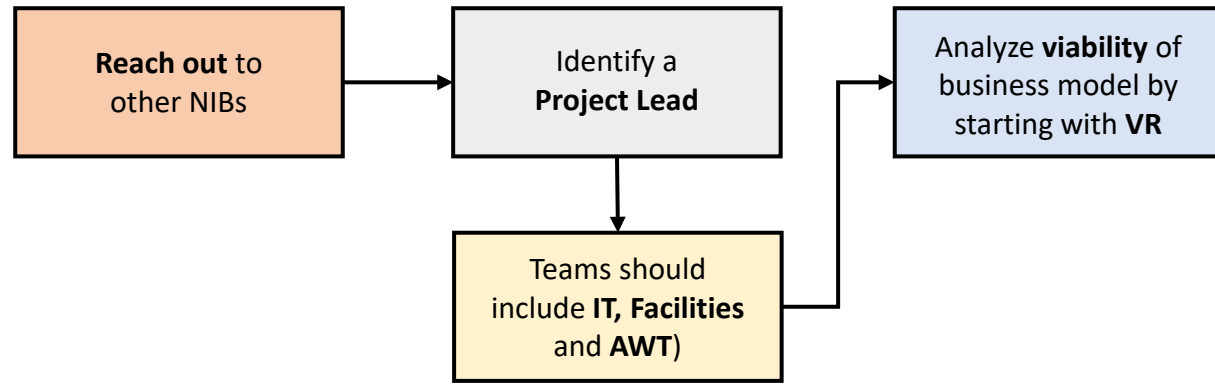

- Next Steps for **Call Center**:

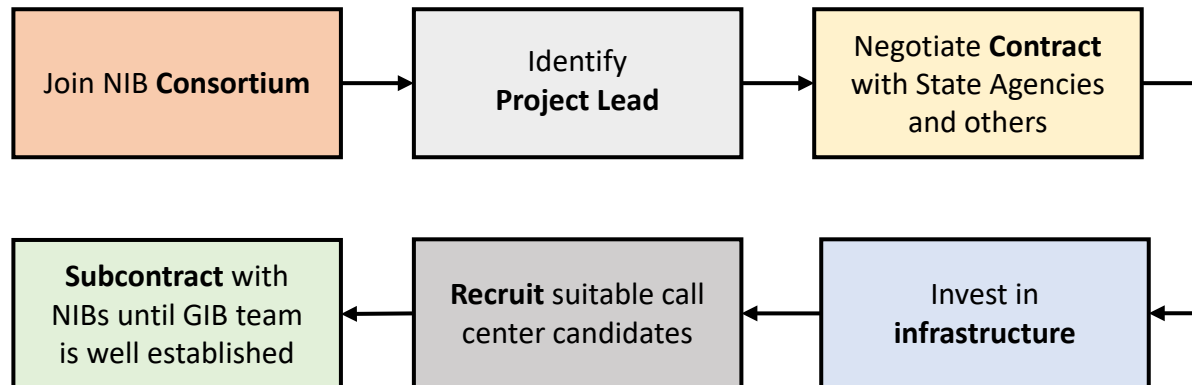

GVRA



Georgia Vocational
Rehabilitation Agency

How does GIB make it's operations Blind-Friendly?



Georgia Vocational
Rehabilitation Agency



GIB Mask Machine Operation

Bainbridge Plant

GVRA



Georgia Vocational
Rehabilitation Agency



- Individually wrapped masks
- 100% Made in the USA
- Five components:
 - Ear Loops: Ohio
 - Nose Wire: Arizona
 - Inner Layer: Georgia
 - Middle Layer: Pennsylvania
 - Outer Layer: Georgia
- Made in Bainbridge, GA by **Blind and Legally Blind Americans**



Plug-in box contains
the voice module with
volume control.
Display is spoken
automatically when
scale reaches
equilibrium.





Georgia Vocational
Rehabilitation Agency

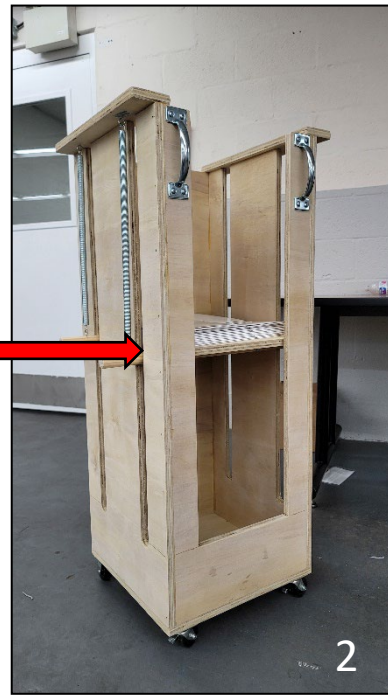
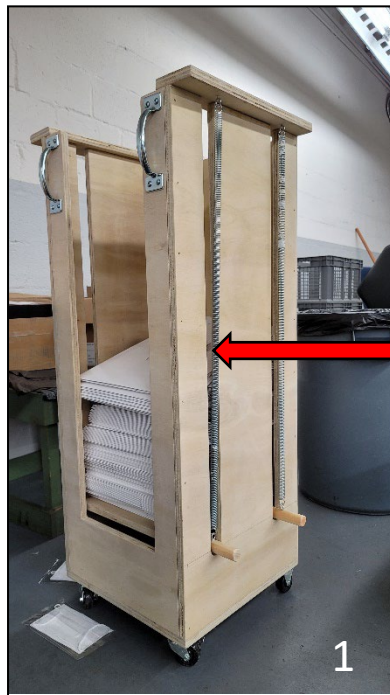



Georgia Vocational
Rehabilitation Agency

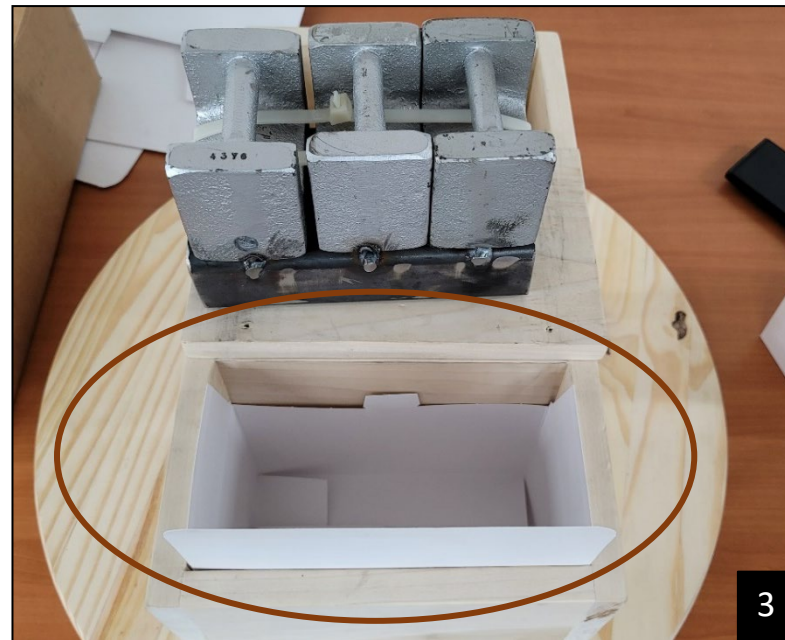
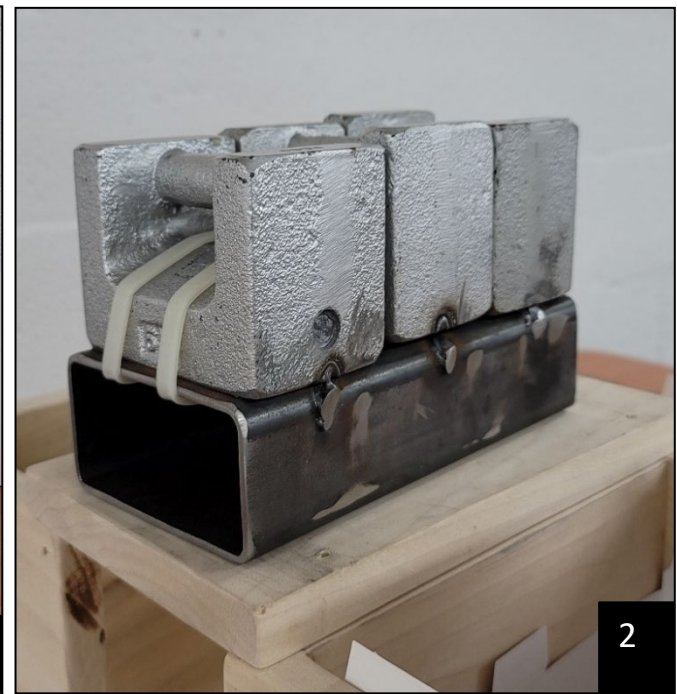



Georgia Vocational
Rehabilitation Agency

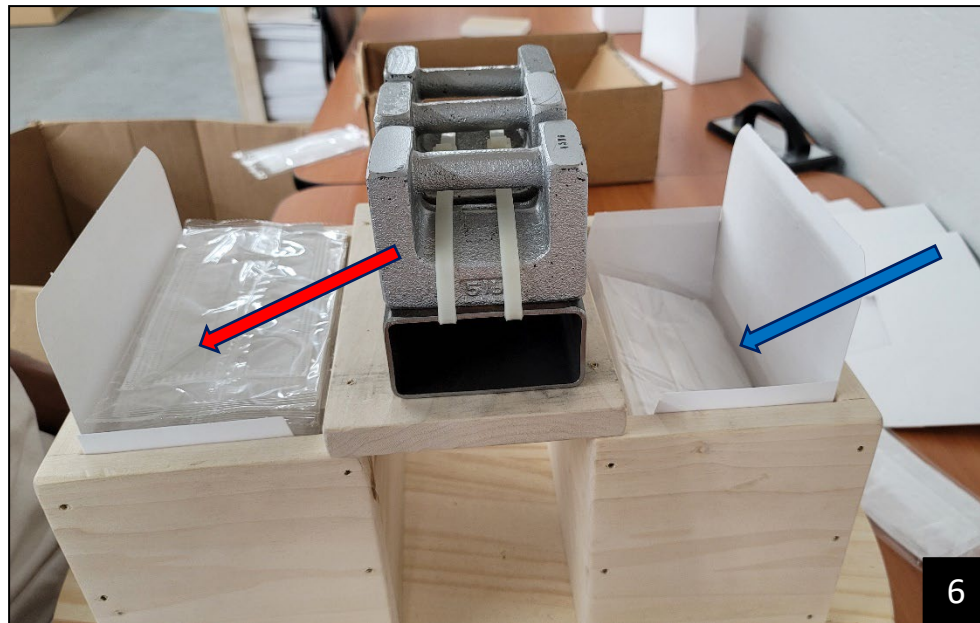
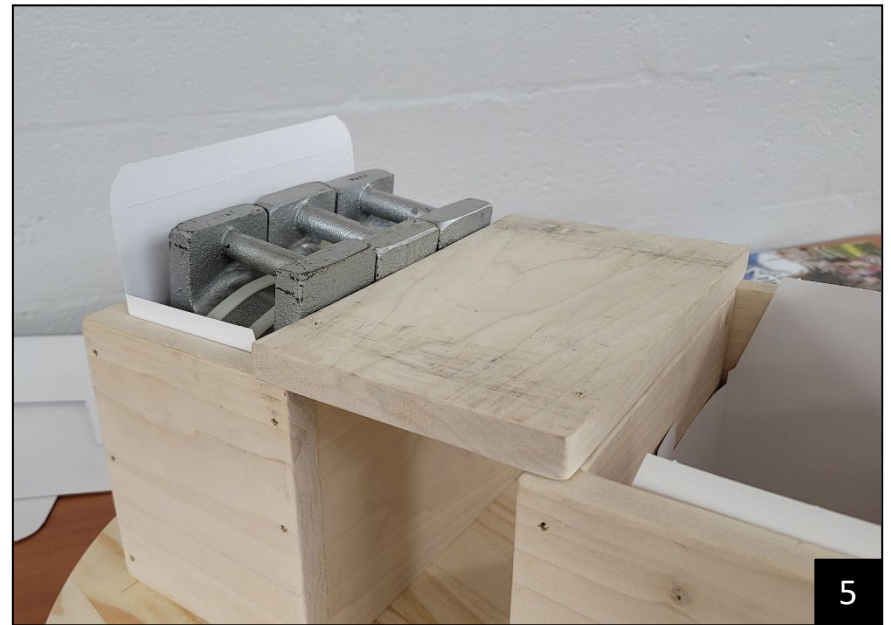
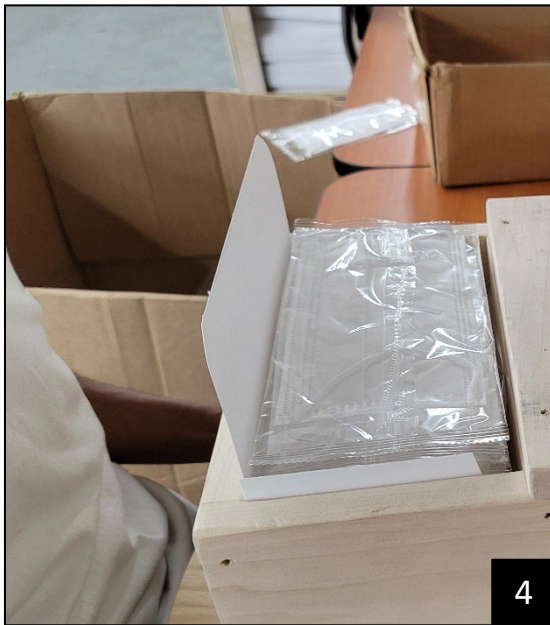

GVRA



Georgia Vocational
Rehabilitation Agency



GVRA



Georgia Vocational
Rehabilitation Agency

Piston Kit Project

GVRA



Georgia Vocational
Rehabilitation Agency

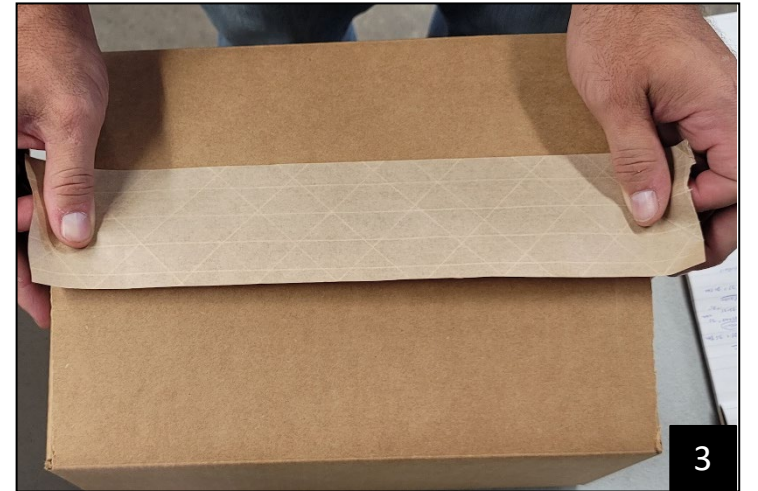

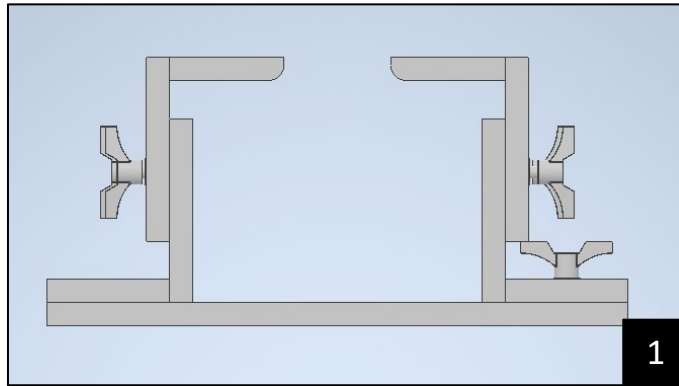

Piston Kit
Box Assembly Fixture
Tabletop Prototype

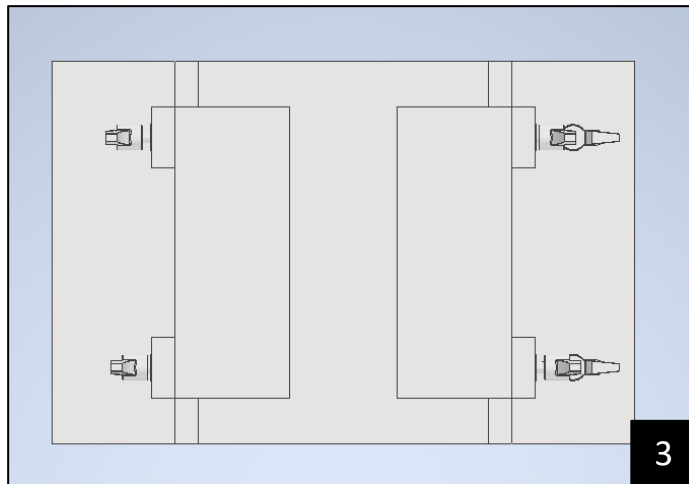
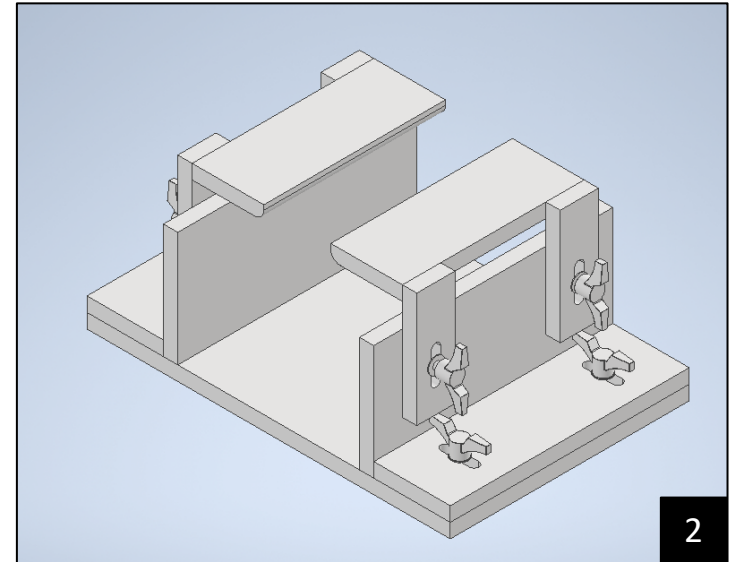



Georgia Vocational
Rehabilitation Agency

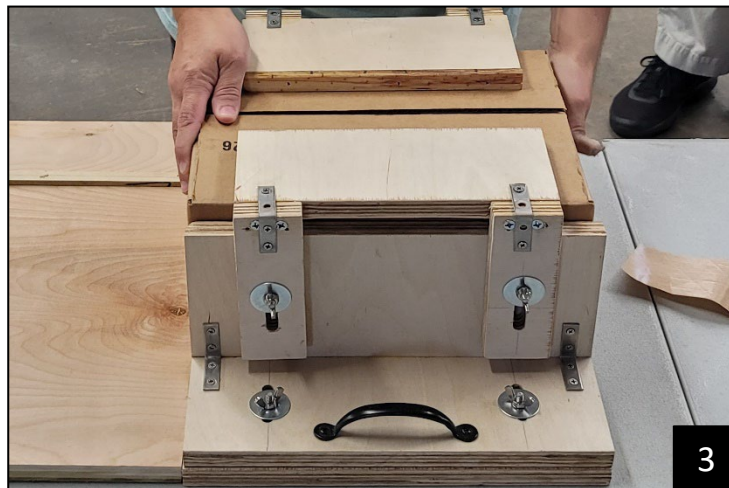



GVRA



Georgia Vocational
Rehabilitation Agency

https://youtu.be/T5G4RETj_pQ

GVRA



Georgia Vocational
Rehabilitation Agency

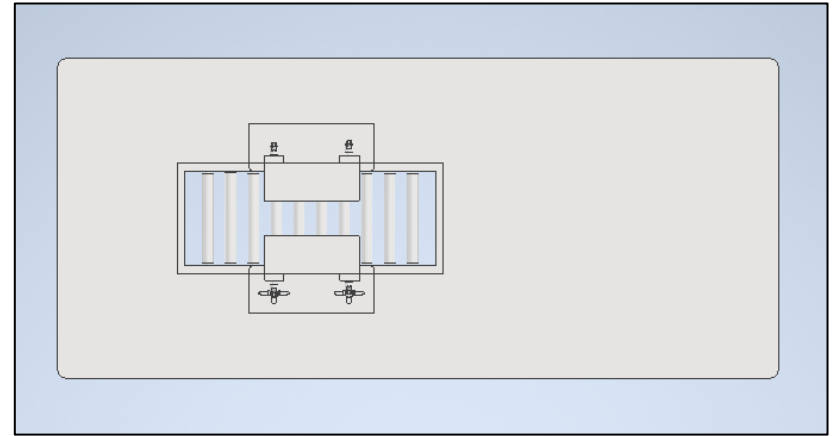
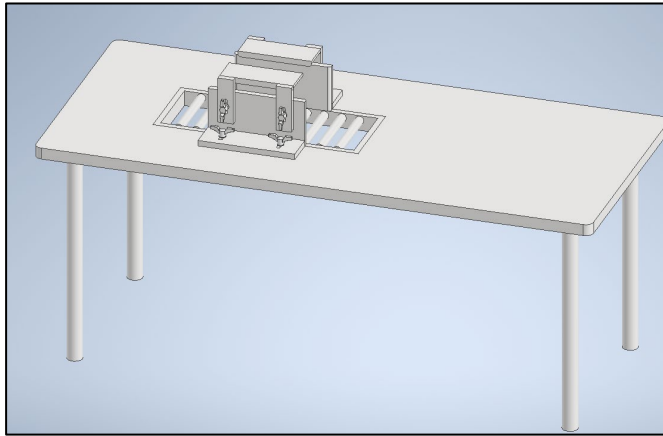

Piston Kit
Box Assembly Fixture
Integrated Table Design

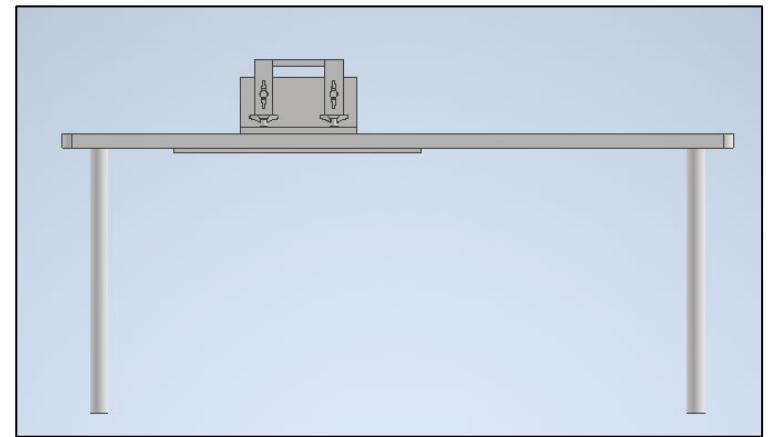
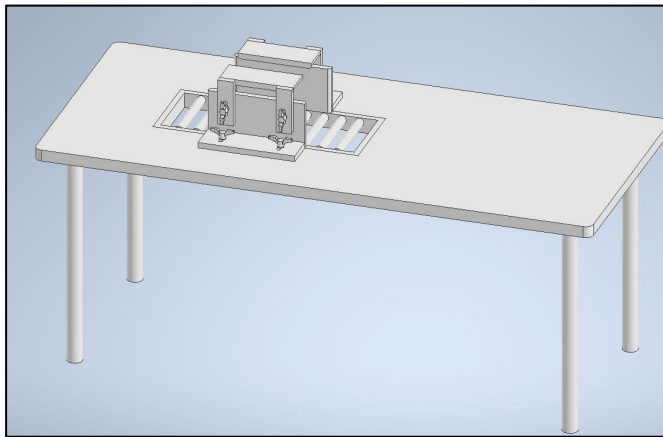



Gravity Flow Racks (With Rollers)

Clear All



Knuckled Skate
Wheel Track
Bolted Stationary
Flow Racks



Straight Skate
Wheel Rail Bolted
Stationary Flow
Racks



Straight Skate
Wheel Track
Boltless
Stationary Flow



Straight Roller
Track Boltless
Stationary Flow
Racks



Knuckled Skate
Wheel Track
Boltless
Stationary Flow

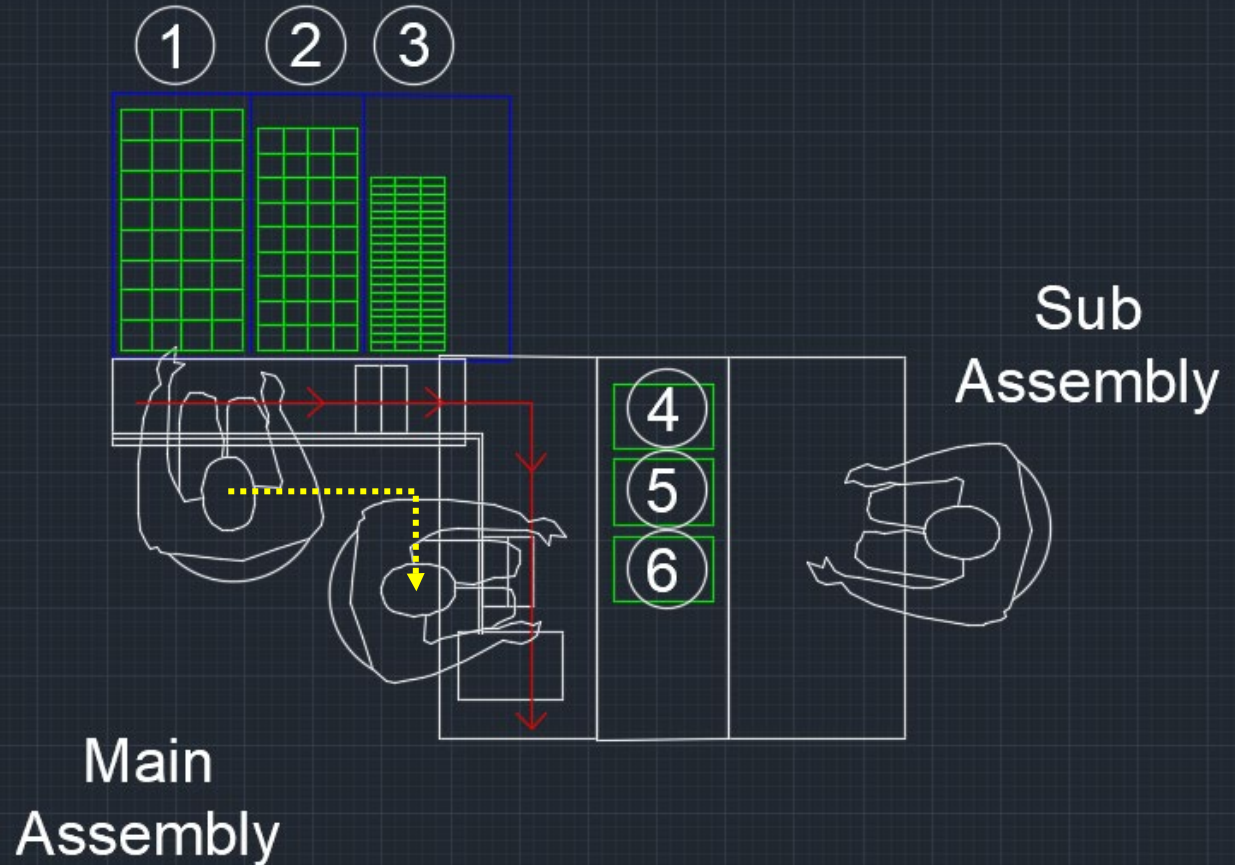

GVRA



Georgia Vocational
Rehabilitation Agency

QUESTIONS?

Continuing Education and Training

Buffy Mitchell, Assistant Director

Raj.Pagadala@gvs.ga.gov



GVRA



Stakeholder's Summit

Ahnieyah Porter, Executive Assistant to the Executive Director

Ahnieyah.porter@gvs.ga.gov



GVRA



Residential Services

Dr. Lee Brinkley Bryan, Director of Residential Services

Lee.bryan@gvs.ga.gov



GVRA





Georgia Vocational
Rehabilitation Agency

Students Served 2016-2020

Roosevelt Warm Springs

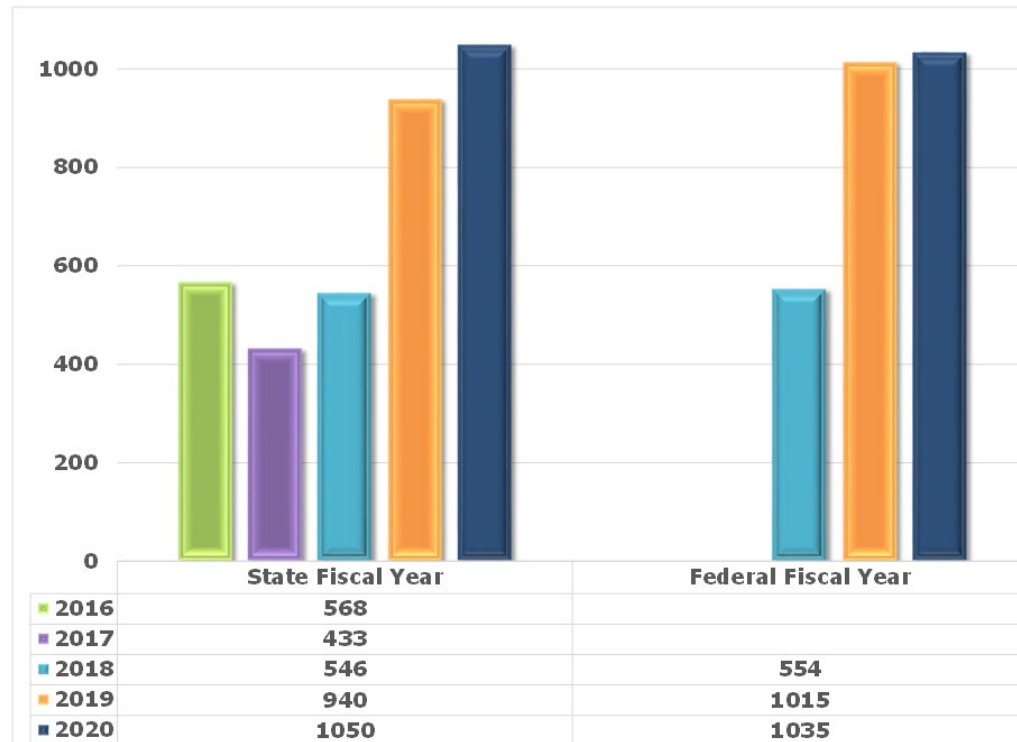



Georgia Vocational
Rehabilitation Agency

Students Served 2016-2020

Cave Spring Center

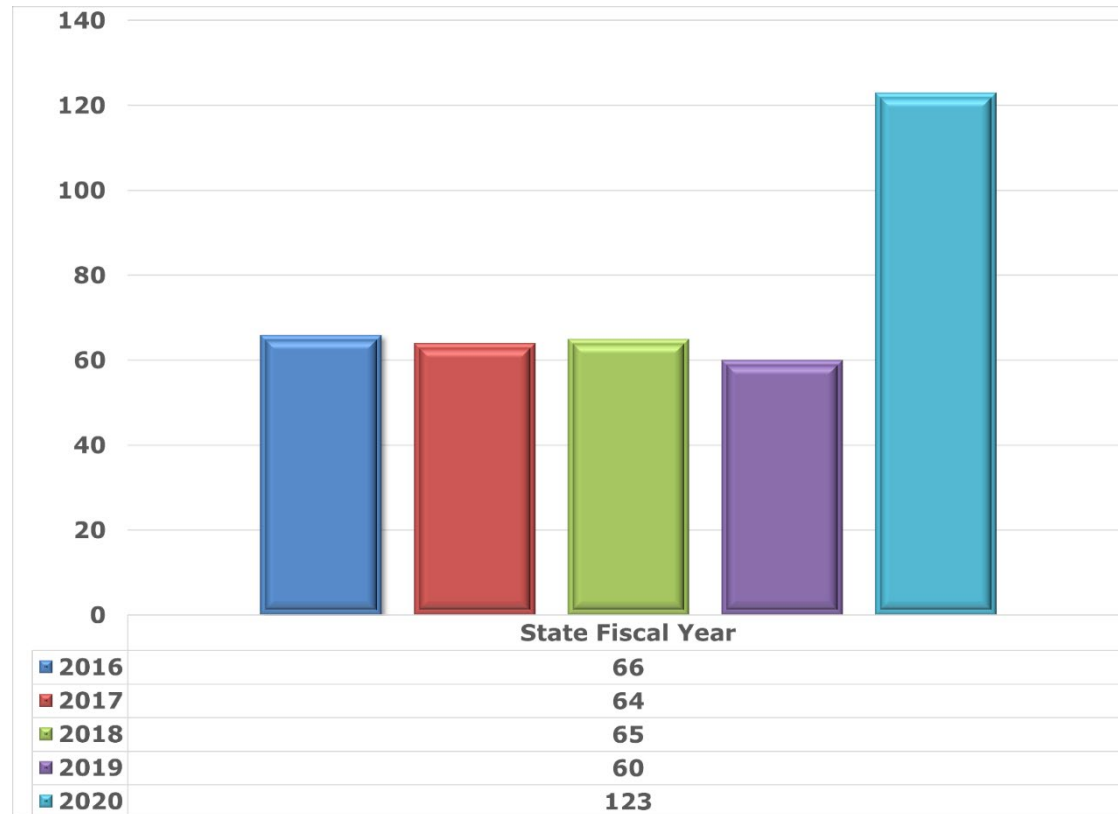

GVRA



Georgia Vocational
Rehabilitation Agency

Academic and Transition Education

Roosevelt Warm Springs

5 Academic Teachers

163 Students Served – Academic Education

101 Students Served – Transition Education

Cave Spring Center

2 Academic Teachers

36 Students Served – Academic Education

Department of Education Funded Position - 1st, 2nd & 3rd Quarter Data



Academic Gains, Skills Gains, and Credential Attainment

Roosevelt Warm Springs

80 Students – Reading (MindPlay)

25% increased by 3 or more grade levels

10 students increased reading skills by 4-5 grade levels

83 Students – Mathematics (Khan Academy)

27% increased by 3 or more grade levels

15 students increased math skills by 4 -5 grade levels

Department of Education - 1st, 2nd & 3rd Quarter Data



Georgia Vocational
Rehabilitation Agency

State and Industry Recognized Certifications

Roosevelt Warm Springs

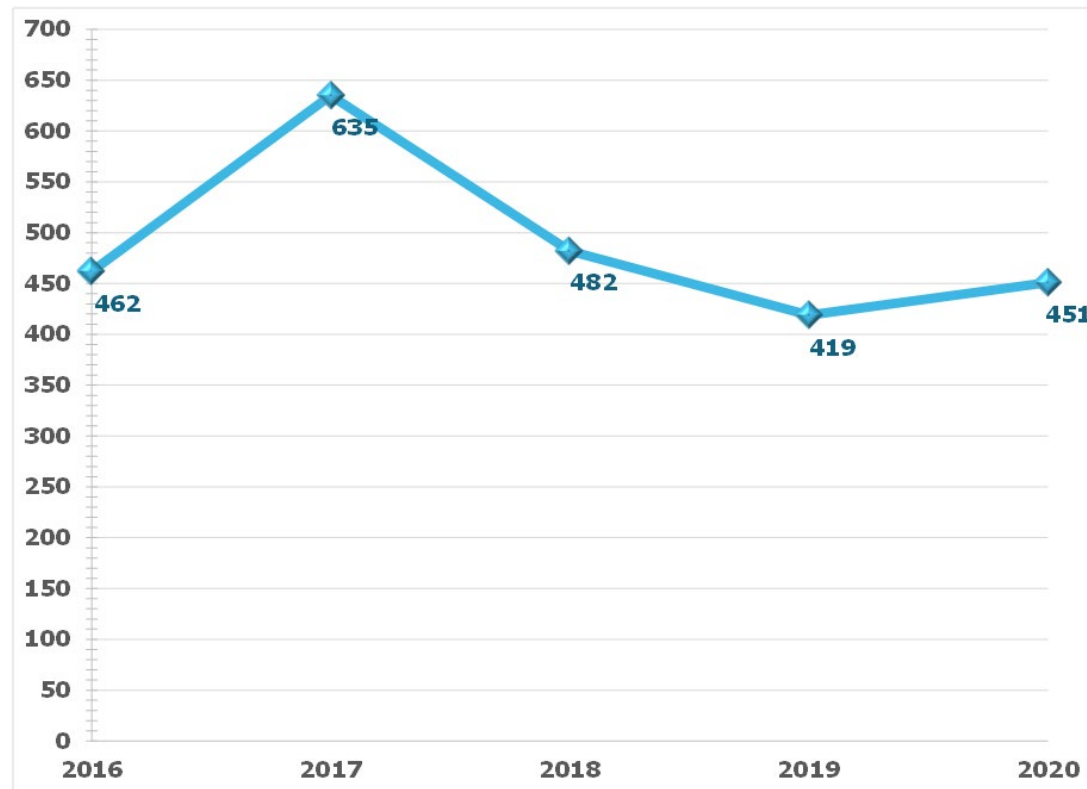

GVRA



Georgia Vocational
Rehabilitation Agency

Pre-Employment Transition Services (Pre-ETS)

Roosevelt Warm Springs

Virtual Services

380 Students

25 area high schools

Cave Spring Center

Virtual & Georgia School for the Deaf

25 Students

2 area high schools



Georgia Vocational
Rehabilitation Agency

Vocational Assessment Services

Roosevelt Warm Springs
Virtual Picking My Path

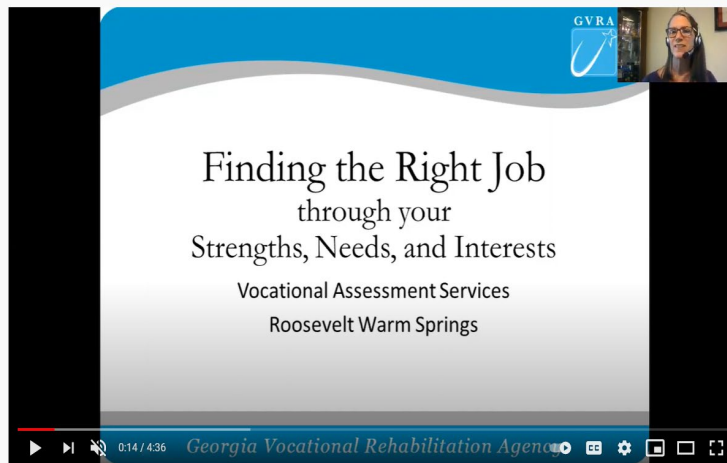

Cave Spring Center
Seeking Your Potential





Georgia Vocational
Rehabilitation Agency

Hanging with EDS

Roosevelt Warm Springs

Virtual Job Club

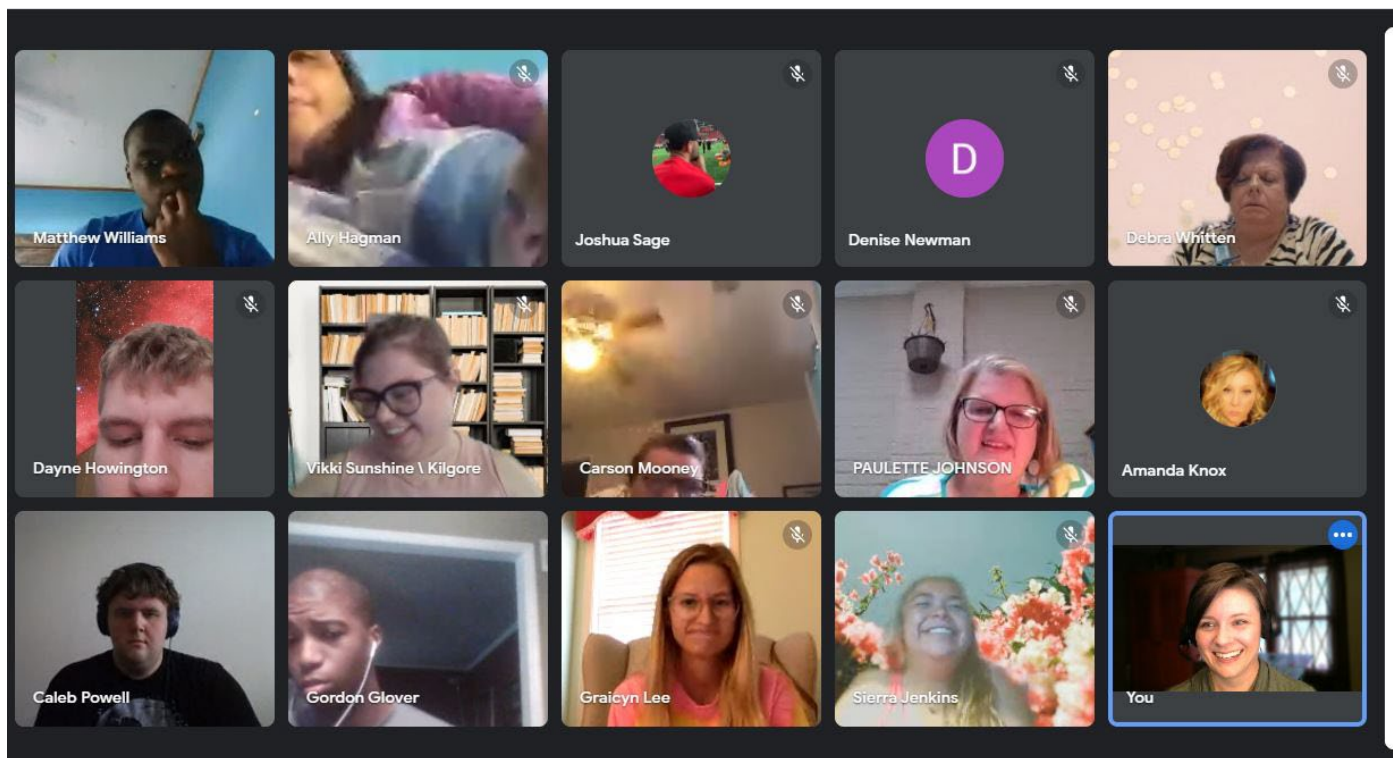



Return to Campus

Roosevelt Warm Springs

- Return to Campus Phase III – A
- 67 bed capacity
- Tracking COVID data
- Preliminary Planning for Phase III - B

Cave Spring Center

- Planning Return to Campus – Phase I
- 14 bed capacity
- Considering day & residential options

GVRA



Georgia Vocational
Rehabilitation Agency

Introductions

Vindarius Davis

RWS Student

Steve Stanfield

RWS Development Board Chairman



Campus Projects

Roosevelt Warm Springs

- Water Tank Renovation
- HVAC Mini-Plant Project
- Portico Replacement – Georgia Hall
- Water Proofing Project - Roosevelt Hall
- Campus Master Planning



GVRA



Georgia Vocational
Rehabilitation Agency

Campus Projects

Cave Spring Center

- Slope Regrading



State Rehabilitation Council

Kate Brady, Chairperson

kate.brady@gvs.ga.gov



GVRA



Executive Report

Chris Wells, Executive Director

chris.wells@gvs.ga.gov



GVRA



Statewide Independent Living Council

Shelly Simmons, Executive Director

SSimmons@silcga.org



GVRA





Board Announcements

- **Old Business**

- None

- **New Business**

- Resolution to approve September Board meeting date change to August.

Public Comments and Adjournment

Tom Wilson, Board Chair

tom.wilson@gvs.ga.gov



GVRA

